



ITAB^{mk}

**EXTERNAL FURNITURE
& ACCESSORIES**

Case Study Education & Commerical Sector

Project - The National Gallery Smoking Shelter
Client – The National Gallery, London
Timing – January 2007

The National Gallery was established in 1824. Designed to be the start of a national collection of paintings, which could be enjoyed by all for free, it quickly grew in size and moved to Trafalgar Square where it has continued to grow and develop into one of the worlds finest collections of Western European art.

The building has had to be changed many times in order to sympathetically house the growing collection. One of these changes is the Smoking Ban which is due to come into force 1st July 2007.



ITAB^{mk}

EXTERNAL FURNITURE & ACCESSORIES

In order to provide a comfortable and clean environment for the people who work in the National Gallery a smoking shelter was thought to be the best and most appropriate solution for the building.

It provides a place to sit and useful cigarette dispensers help to keep it clean, tidy and safe as well as complying with the new law. The smoking shelter itself is not our standard white but painted black to compliment the Gallery.

We have also provided 2 benches as well as the perch seat and 2 smoking bins and all installed in just two days!

The National Gallery praised our professionalism and also added “We are pleased with the quality of the shelter and we welcomed your suggestion to provide the bench seats. Considering that our order was placed just before the Christmas holiday, you did well to deliver and install so early in January. The black frame was the right decision”

69. Trolley Shelter

This aluminium trolley shelter has high resistance against corrosion & comes complete with special tarmac fixings. It has a superior quality appearance with concealed edges for glazing and is low maintenance. The roof is glazed with translucent sheets & is secured within an aluminium frame with steel or aluminium fascia panels (which can be painted to any RAL colour choice to suit). Logo panels are also available with lettering included (standard is a Trolley Symbol) - colour choice to match roof ends. The glazing side panels come as 5mm PET with 6mm polycarbonate roof panels, tinted are available at extra cost. Our standard covered trolley shelter is a robust, durable construction designed to fit a standard car park space. The shelter has the added benefit of being able to be bolted to tarmac with no structural ground works required as we use special tarmac fixings, which makes this shelter very cost effective and very simple to install. Units can be installed end-to-end or side-by-side to create larger areas for trolley storage. It also features a trolley harness rail and interior & exterior crash-rails to protect against trolley or vehicular collision damage.

Standard and optional features;

Design:

- “Trolley Shelter can be surface fitted to standard car park tarmac surfaces with no structural ground works”
- Standard size 4334mm long x 2360mm wide x 2200mm height
- Shelter is constructed from aluminium and steel with PET side/end panels
- Polyester finish and comes in white as standard, other colours are available on request
- 334mm roof overhang is constructed of polycarbonate roofing sheets
- Internal trolley harness rail is installed for guidance and protection of trolleys
- Interior and exterior crash rails are fitted to protect

ITAB^{mk}

EXTERNAL FURNITURE & ACCESSORIES

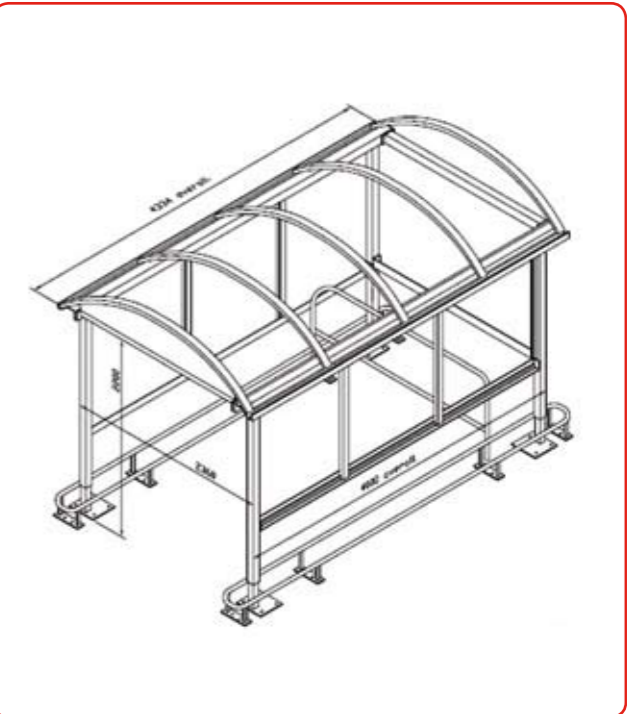

70. Radpark

against trolley or vehicular damage

- Special guttering extrusion with clever attachment built-in which holds heads of the bolts
- Optional back end panels also available + hitch rail to be used with trolley locks
- Galvanised steel trolley harness rails
- Materials used for the roofing and side panels comply with Flammability Classifications BS 476/7 for the roofing sheets and UL94 (rating V2) for the side panels. Both are self extinguishing

Order Information

Can be supply only or fully installed. Please specify at time of order any additional extras the Trolley Shelter may need.

Radpark is an economical yet robust Trolley Shelter, constructed from extruded aluminium sections. Tough PET glazing panels locate into channels in the extrusion, providing a sleek and contemporary design. The front fascia panel provides an ideal location for signage or logos. Our modular designed shelter is a robust, durable construction and fits into a standard car park space. Installation is simple with no special fixing requirements. Built-in interior & exterior crash-rails are included to protect against trolley or vehicular collision damage.

Standard and optional features;

Design:

- Standard size 4189mm long x 2276mm wide x 2519mm height
- Shelter is constructed from aluminium frame and steel crash bar with PET roof/side/end panels –UV screen on one side
- Finish Anodised - Silver
- Built-in interior and exterior crash rails are fitted to protect against trolley or vehicular damage , mild steel hot galvanised finish
- Zone roof signage is also available as an optional extra
- Accommodates 3 trolleys side by side
- PET sides can be used for housing advertising
- End back glazing panel can be removed to create a back to back trolley housing
- Comes complete with yellow flexible PVC bump strip to retain trolleys in shelter

Order Information

Can be supply only or fully installed.

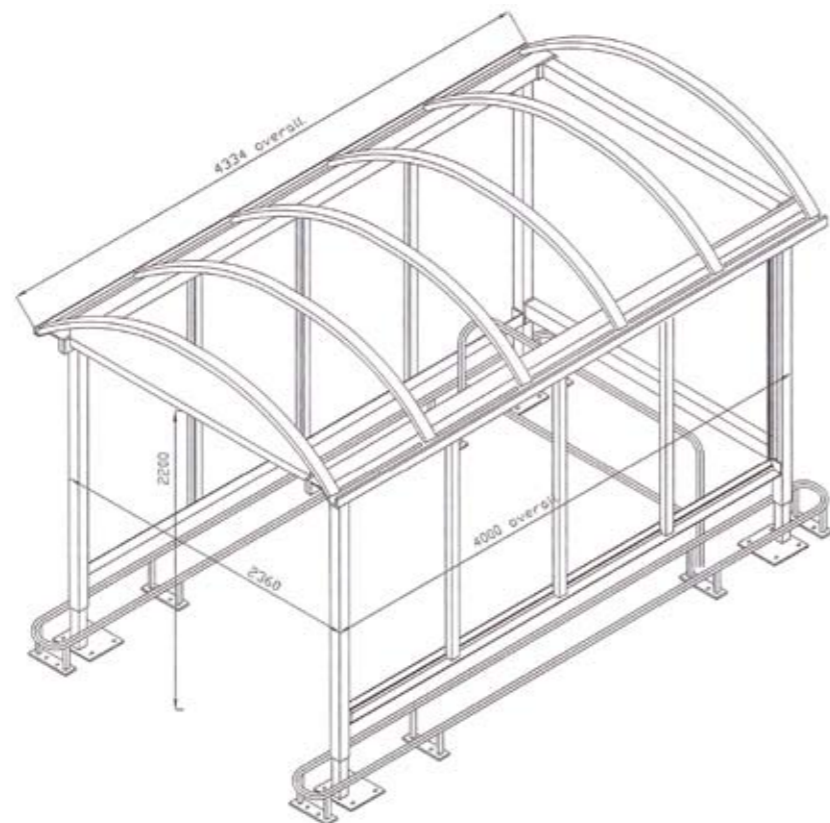
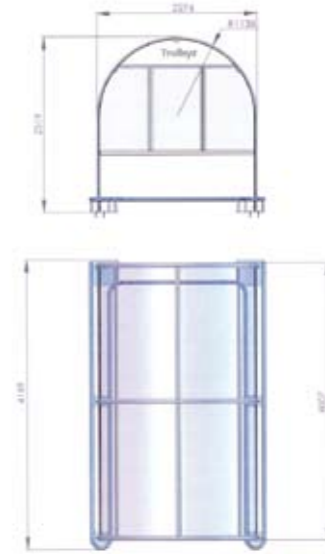

71. Mobile Trolley Parks

ITAB^{mk}

EXTERNAL FURNITURE & ACCESSORIES

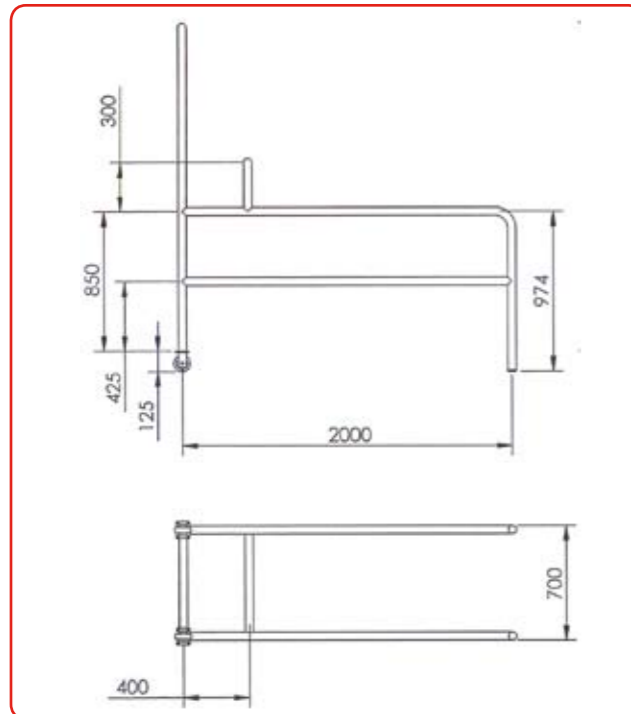

Our mobile trolley parks provide the perfect, low-cost solution to flexible trolley storage. Mounted on lockable castors the parks can be easily re-located either internally or externally, providing a superb level of versatility to meet your individual needs. Manufactured from 50mm diameter stainless steel tubular section, the mobile trolley park provides a robust, rust proof solution for trolley control, where space is at a premium. The unit is light weight and easily manouverable, so can be conveniently located at the store entrance and put away when the store is closed. The mobile trolley bay is 2m in length, allowing for storage of approximately 10 standard trolleys and removes the need for any kind of planning permission.

Standard and optional features;

Design:

- Lockable Castors
- Lightweight and easily moved on castors (Weight 42kg)
- Versions available: 2" diameter tubular stainless steel
- 2m long x 700mm wide
- Optional sign panel

Order Information

Available Supply Only



72. Canopy Shelter

ITAB^{mk}

EXTERNAL FURNITURE & ACCESSORIES

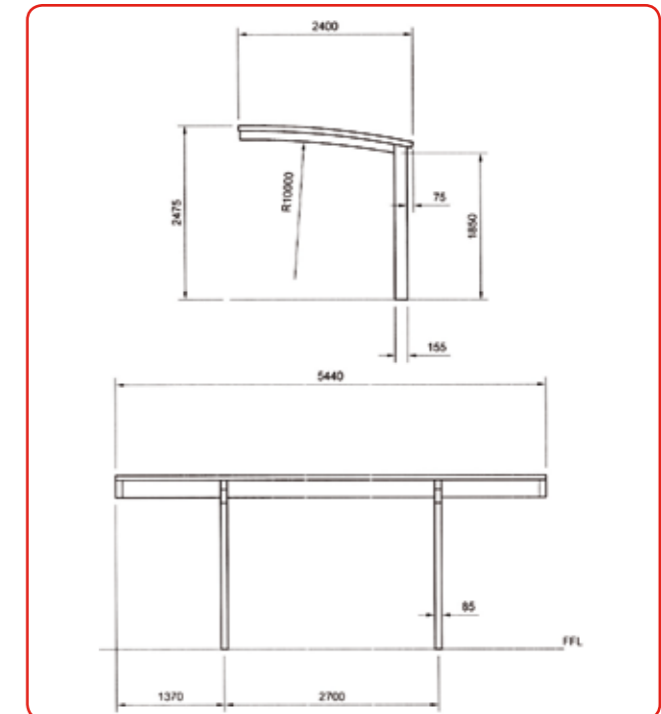

Our canopy shelter with its heavy duty roofing, can withstand loading up to several tons and will enhance your outdoor living space with its versatility. This multi purpose shelter provides protection from all weather conditions. Its modular design allows multiple units to be fitted together to form a continuous shelter or covered walkway. Manufactured from an aluminium and steel frame with glazed translucent polycarbonate roof panels (6mm thick) which gives the shelter its unrivalled durability. The modular design of the Canopy Shelter allows for multiple unit to be linked together to create continuous runs for walkways. The steel support legs are designed to be potted into a concrete base to give the structure superior strength and rigidity.

Standard and optional features;

Design:

- Standard size 5440mm long x 2200mm wide x 1550mm height
- Shelter is constructed from aluminium frame and zinc-coated galvanised steel construction with glazed translucent polycarbonate roof panels
- Polyester finish and comes in white as standard, other colours are available on request
- Units can be easily adapted and installed end to end or side by side to create large areas or covered walkways with appropriate joining pieces. The frame can also be painted to any RAL colour to suit
- Comes with plastic gutting and drainage for efficient dispensing of weather residue
- Wide range & choice of roofing panels are available as options

Order Information

Can be supply only or fully installed. Confirm configuration & options at time of order.



73. Covered Walkway

ITAB^{mk}

EXTERNAL FURNITURE & ACCESSORIES

ITABmk manufacture a range of walkway products, based around our standard shelter components. This provides a highly competitive and versatile solution which can be tailored to meet most requirements.

Constructed from aluminium extruded section, the system incorporates an integral guttering, running the full length of the walkway. Stainless steel tube links the guttering into the support legs to allow rain water to disperse via a weep hole at the bottom of the leg. Roof panels are produced from twin walled polycarbonate sheets fitted into rolled aluminium roof beams. Additional cross braces give the system added support and rigidity. The walkway is designed to be surface fixed to concrete pads or suitable ground substrate.

Standard and optional features;

Design:

- Walkway is constructed from aluminium frame and zinc-coated steel construction with glazed translucent polycarbonate roof panels
- Silver anodized finish. Powder coated colours are available on request
- Units can be easily adapted and installed end to end or side by side to create large areas. Comes with plastic gutting and drainage for efficient dispensing of weather residue
- Tough polycarbonate roofing panels are available as options

Order Information

Can be supply only or fully installed. Confirm configuration & options at time of order.



74. Multi-Purpose Shelter – Small or Large

ITAB^{mk}

EXTERNAL FURNITURE & ACCESSORIES

This aesthetically pleasing shelter is manufactured from high grade components and provides an ideal solution for many needs whether this be a covered walkway to connecting corridors between buildings to bus shelters. Units can be easily adapted and installed end-to-end or side-by-side to create larger areas. The frame can also be painted any RAL colour to suit.

The superior design gives unrivaled protection from all weather conditions. Constructed from aluminum section, the shelter offers unmatched resistance to corrosion, coupled with low maintenance. The roofing is glazed with 6mm translucent polycarbonate sheeting for outstanding durability, and is secured within the aluminium frame. Each side panel is glazed in 5mm PET and has carefully concealed edges. Tinting is available at extra cost, as is toughened safety glass.

The shelter is supplied with all fixings and can be tailored to individual requirements. Colours can be altered and logo panels can be supplied to suit. Units can be readily adapted and installed end-to-end or side-by-side to create larger areas. A large (4334mm in length) shelter unit is also available.

Standard and optional features;

Design:

- Small size 2405mm long x 2360mm wide x 2200mm height
- Large size 4334mm long x 2360 wide x 2200 height
- Shelter is constructed from aluminium frame and zinc-coated galvanised steel construction
- Polyester finish and comes in white as standard, other colours are available on request
- Floor fixed with vandal resistant PET glazing & polycarbonate sheet roofing

Order Information

Can be supply only or fully installed.



75. Smoking Shelter – Standard

ITAB^{mk}

EXTERNAL FURNITURE & ACCESSORIES



This aesthetically pleasing shelter is manufactured from high grade components and provides a splendid solution for helping to promote a smoke free environment in the workplace, whilst providing smokers with superior protection from all weather conditions and it fully compliant with the new legislation that will be enforce as of 1 July 2007 across England. Generously proportioned, the shelter is constructed from aluminium (complies with BS EN ISO 1461 standards of weather resistance) resulting in high resistance to corrosion, coupled with low maintenance.

The roof is glazed with twinwall translucent polycarbonate sheets (6mm thick) which are secured within the aluminium construction. This gives the shelter unrivaled durability.

The side panels are glazed with 5mm UV stable PET and are UV stable. 5mm polycarbonate and can be tinted at extra cost. Toughened safety glass is also available if required.

Units can be easily adapted and installed end-to-end or side-by-side to create larger areas. Other colours are available on request but will be subject to lead times & an additional charge. The shelter is supplied with all fixings. Top quality seating, signage and cigarette bins are also available as extras.

Standard and optional features;

Design:

- Standard size 4334mm long x 2360mm wide x 2200mm height
- Shelter is constructed from aluminium construction
- Polyester finish and comes in silver (RAL 9006) as standard, other colours are available on request
- Floor fixed with vandal resistant PET glazing & polycarbonate sheet roofing

Order Information

Can be supply only or installed by Installation team.



76. Stainless Steel Loops

ITAB^{mk}

EXTERNAL FURNITURE & ACCESSORIES

Our stainless steel loops are factory-cut and finished to the highest quality. The 304 stainless steel loop ends are multi purpose and are available in a number of lengths & heights which can then be put to many uses. Being aesthetically pleasing and extremely durable they are perfect as cycle loops (the potted loop is especially suited to motorcycles). The loops may also be used in a variety of other applications including demarcation areas (especially trolley bays) and as doorway or wall protectors. They are available either surface fixed or potted (300mm below ground level) to suit location requirements.

Standard and optional features;

Design:

- 60mm diameter stainless steel tube which can be potted or surfaced fixed rails
- 3 sizes available (1m/1.5m/2m)

Order Information

Specify length + potted or surface fixed at time of placing order

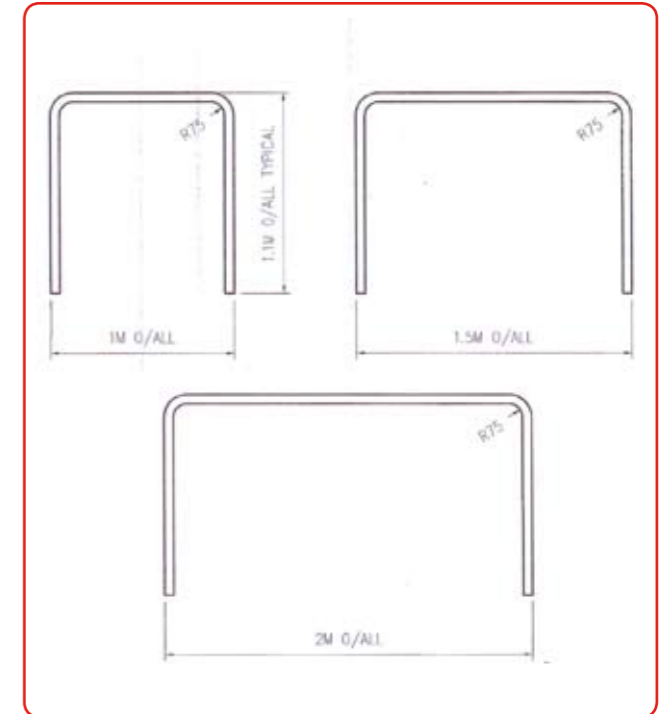

77. Cycle Rack - Basic

ITAB^{mk}

EXTERNAL FURNITURE & ACCESSORIES



Our basic cycle rack is one of those ideal systems for securing and storing bicycles and offers a typical cycle capacity. It is a heavy-duty rack with a six cycle capacity. Manufactured from galvanised steel for extra corrosion resistance. This complete modular system can be installed back to back, or side by side to further boost number of cycle spaces available. Ideal applications for this cycle rack are car parks, stations, schools, colleges, etc.

Standard and optional features;

Design:

- Cycle Capacity: 6
- Overall Dimensions: 2400mm length x 650mm height x 550mm width
- Maximum Tyre Width: 50mm
- Clearance between bicycles: 45mm

Order Information

Can be provided as supply only or fully installed



78. Cycle Rack - Upright

ITAB^{mk}

EXTERNAL FURNITURE & ACCESSORIES

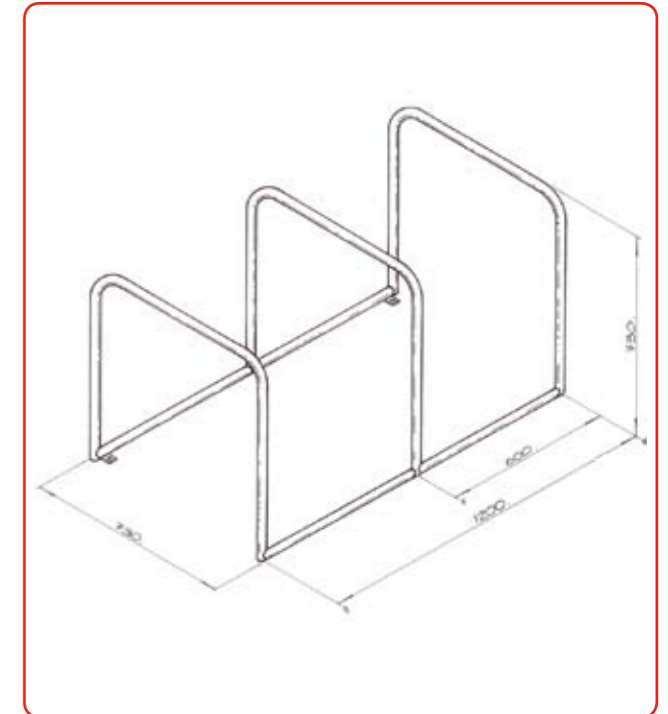

Our modular cycle rack is perfect for providing a simple, cost-effective solution to cycle storage. We understand that every environment has a different level of requirement for cycle storage space. These racks can be ordered individually or in other quantities to form an extended cycle storage area. Made from high quality stainless steel, our cycle rack is both weather resistant and extremely durable. Each rack is floor fixed for extra rigidity. A generous gap of 600mm between uprights means the rack is suitable for all types of cycles

Standard and optional features;

Design:

- Construction: 304 grade stainless steel
- Surface fixed or potted support foot
- Dimensions: 730mm height x 730mm depth x 1200mm width (bicycle clearance 600mm)

Order Information

Can be provided as supply only or fully installed



79. Cycle Rack - Dual Level

ITAB^{mk}

EXTERNAL FURNITURE & ACCESSORIES

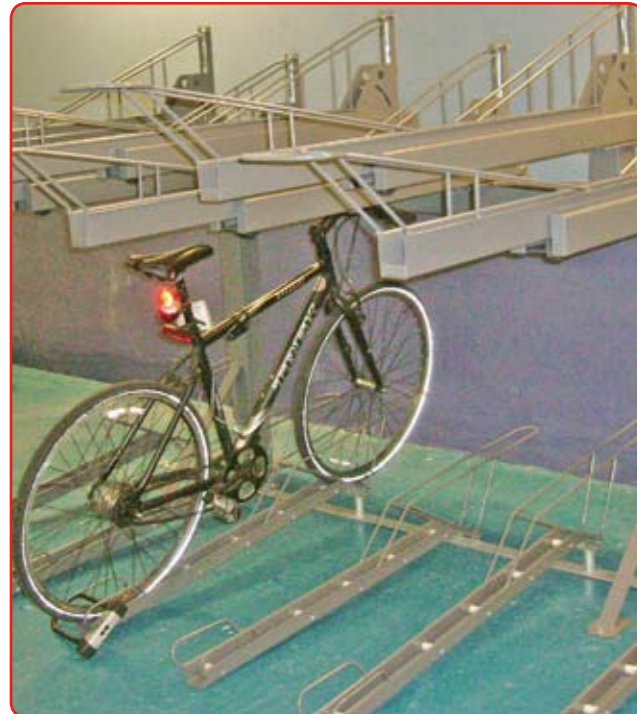

Our dual level cycle rack is one of those ideal systems for securing and storing bicycles. It is a heavy-duty rack with a twelve cycle capacity with its unique arrangement of upper & lower alignment to maximize your storage. Manufactured from galvanized steel for extra corrosion resistance. This complete modular system can be installed back to back, or side by side to further boost number of cycle spaces available. This cycle rack offers a new dimension to bicycle parking with a combination of style and maximum security. The position of the frame and bars enables bikes to be secured by frame and wheel with a single 'U' lock. Ideal applications for our dual level cycle rack are where space is at a premium; train stations, bus stations, car parks, etc.

Standard and optional features;

Design:

- Cycle Capacity: 12
- Overall Dimensions: 2450mm length x 1680mm height x 2000mm width
- Maximum tyre Width: 50mm
- Clearance between bicycles: 45mm
- Galvanised steel

Order Information

Available Supply Only or fully installed



80. Perch Seat

ITAB^{mk}

EXTERNAL FURNITURE & ACCESSORIES

Our stainless steel perch seat has been especially designed to perfectly compliment our range of shelters, providing a pleasant addition to the environment. Stainless steel in construction, it is both stylish in appearance and comfortable to use. Each bench unit is 1.8m long, and two can easily be installed together to fit our larger shelters. This perch seat is extremely durable and weather proof. Being floor-fixed or potted, it is also highly robust.

Standard & optional features:

Design:

- Stainless steel construction
- Available in 1.8m units
- Superb durability
- Class 1 surface spread of flame to BS476
- Is available surface fixed or potted

Order Information

Can be supply only or sold with our range of shelters.

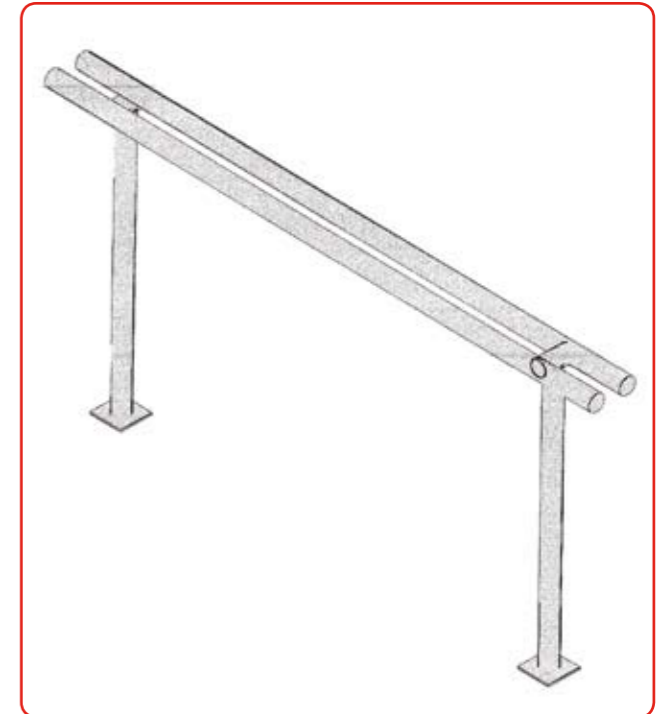

81. Recycled Plastic & Steel Bench

ITAB^{mk}

EXTERNAL FURNITURE & ACCESSORIES



Our outdoor seat is hugely popular with our customers and used wherever a hard wearing, comfortable and attractive seat is required.

It has a generous length of 1800mm, typically giving space for up to 4 people to sit in a restful environment. The seat combines 5 recycled plastic wedges, each 150mm wide, ensuring a comfortable and supportive base. The frame is made from extremely strong 50mm steel giving superb durability, and is easily bolted to the floor.

Ideal applications are parks, school play grounds, colleges, etc. where hard wearing seating is required to withstand all the elements.

Standard and optional features;

Design:

- Overall seat length 1800 mm
- Wedge section 45/55 taper x 150 mm wide
- Wedge section seating slats bolted onto the frame
- 5 wedges per seat, 3 on base, 2 on back
- 50 mm hollow box section, steel

Order Information

Delivered complete.



82. Shopping Baskets – 20 & 26 Litre

ITAB^{mk}

EXTERNAL FURNITURE & ACCESSORIES



Our tough polypropylene basket with glass fibre reinforced handles are designed to project a modern day image that can easily within stand the rigours of the everyday shopping experience. These baskets are extremely durable with a choice of either a 20 or 26 litre versions which offer high capacity. They are also available in a selection of colours so can be tailored to reflect the corporate/brand image of the interior of the store. They are strong and easy to stack without being bulky with a positive handle locking action. There is the added benefit of the basket ends or sides can be printed with company logos or any advertising material for an even greater impact on the customer. A choice of two high capacity shopping baskets manufactured from tough polypropylene. Both easily cope with the rigours and strains of everyday shopping.

Standard and optional features;

Design:

- Construction: Tough polypropylene with glass fibre reinforced handle
- Stock colours are red, blue, green & white but options are available, please ask
- Dimensions: 440mm/480mm length x 310mm width x 210mm height

Order Information

Available Supply Only



83. Static Basket Stacker

84. Mobile Basket Stacker

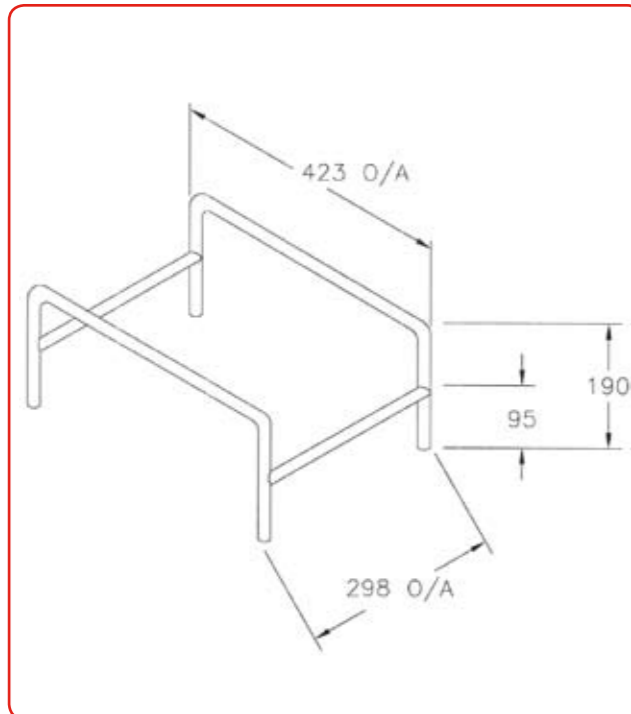

Our basket stackers are designed to provide efficient and effective storage for a stack of baskets, keeping them tidy and discreetly out of the way to avoid any damage. This static version lets you keep baskets in one place, so you'll always know where to find them.

Standard and optional features;

Design:

- Is available to fit a 20 litre and 26 litre shopping basket
- Construction: steel tube
- Finish: chrome

Order Information

Available Supply Only

Our basket stackers are designed to provide efficient and effective storage for a stack of baskets, keeping them tidy and discreetly out of the way to avoid any damage. This mobile version which is mounted on to 4 castors, enables easy transportation from a checkout collection to the point of entry without the requirement for any heavy lifting.

Standard and optional features;

Design:

- Is available to fit a 20 litre and 26 litre shopping basket
- Construction: Mild Steel
- Finish: chrome
- Fitted with 4 castors to aid mobility

Order Information

Supply Only



85. Cigarette Bin – Standard

ITAB^{mk}

EXTERNAL FURNITURE & ACCESSORIES



Our stainless steel cigarette bins are the perfect compliment to our range of smoking shelters. Each bin ensures that cigarette butts are kept out of sight, discouraging litter and making a safe and hygienic smoking area. The bin has a front grill designed to allow cigarette butts to be placed inside, where a specially designed collection box reduces smoke return and fire hazard. The bin is both easy to empty and clean and comes complete with a lock & key for added security.

Standard & optional features;

Design:

- Bins are constructed from satin polished 304 grade stainless steel
- Bin dimensions: 280mm high x 260mm wide x 110mm depth
- Removable Internal Tray Size: 140mm high x 210mm wide x 90mm depth
- Thickness 0.6mm
- All fixings are included
- Weight: approx. -2kgs

Order Information

Supply only or fully installed with smoking shelters



86. Cigarette Bin – Recessed

ITAB^{mk}

EXTERNAL FURNITURE & ACCESSORIES



Each bin ensures that cigarette butts are kept out of sight, discouraging litter and making a safe and hygienic smoking area. The bin has a front grill designed to allow cigarette butts to be placed inside, where a specially designed collection box reduces smoke return and fire hazard. The bin is both easy to empty and clean and comes complete with a lock & key for added security.

Standard & optional features;

Design:

- Bin is constructed from satin polished 304 grade stainless steel
- Bin dimensions: 375mm high x 320mm wide x 100mm depth
- Removable Internal Tray Size: 140mm high x 275mm wide x 80mm depth
- Thickness 0.6mm
- All fixings are included
- Weight: approx. -2.7kgs

Order Information

Supply only or fully installed with smoking shelters



87. Cigarette Bin - Floor Mounted

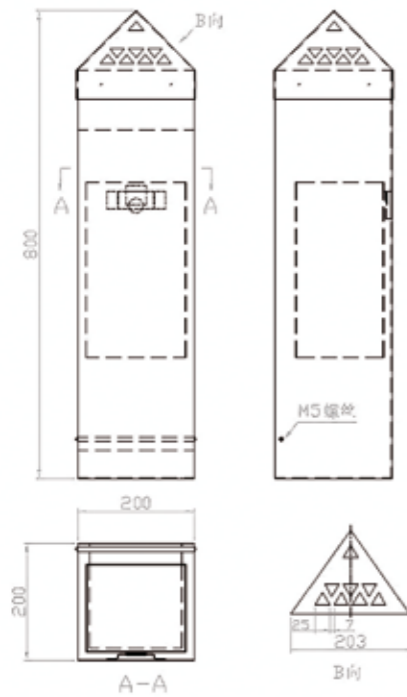

Take a look at our latest addition to our range of cigarette bins. This floor mounted version ideally compliments the rest of our wall mounted cigarette bin range we have on offer, so where no wall space is available this is the perfect solution to used cigarette butts.

Each bin ensures that cigarette butts are kept out of sight, discouraging litter and making a safe and hygienic smoking area. The bin has a top grill designed to allow cigarette butts to be placed inside, where a specially designed collection box reduces smoke return and fire hazard. The bin is both easy to empty and clean and comes complete with a lock & key for added security. Holes are pre-drilled in the back and base for secure fixing.

Standard & optional features;

Design:

- Bins are constructed from satin polished 304 grade stainless steel
- Bin dimensions: 800mm high x 200mm wide x 200mm depth
- Removable Internal Tray Size
- Thickness 1.2mm
- All fixings are included
- Weight: approx. - 6kgs

Order Information

Supply only or fully installed with smoking shelters



ITAB^{mk}

CMB House, Sherbourne Drive, Tilbrook
Milton Keynes, Buckinghamshire
MK7 8BA, United Kingdom

Phone +44 1908 366688
Fax +44 1908 368811
Email sales@itabmk.com
Web www.itabmk.com

We reserve the right to change our
product specification as necessary.